



STAINLESS-AD

LAVATORY BSNK 3



STAINLESS AMERICAN DESIGNS, INC.

### characteristics

material	s. steel
type	304
gauge	18 (1.2 mm)
finish sink	p3
finish bowl	2b

### mounting system

02 built in mounting brackets
04 2" x 3/8" Ø plastic anchors
04 2" x 1/4" Ø screws

### measures

triple station	
length	71.0" ( 180 cm)
width	23.6" ( 60 cm)
height	14.2" ( 36 cm)

### features

- .seamless welded
- .vandal resistant
- .to be used in schools, clinics, hospitals, etc.

[www.stainlessad.com](http://www.stainlessad.com)

4673 Osborne Dr,  
El Paso TX, EUA  
(915) 330-0092,  
(915) 330-0093



STAINLESS-AD

LAVATORY BS NK 3



### **characteristics**

material s. steel  
type 304  
gauge 20 (0.9 mm)  
finish 2b

### **measures**

triple station  
length 71.0" ( 180 cm)  
width 23.6" ( 60 cm)  
height 14.2" ( 36 cm)

### **mounting system**

02 built in backup levelers  
02 2" x 3/8" Ø plastic anchors  
02 2" x 1/4 Ø screws

### **features**

.seamless welded  
.vandal resistant  
.to be used in schools,  
clinics, hospitals, etc.

[www.stainlessad.com](http://www.stainlessad.com)

4673 Osborne Dr,  
El Paso TX, EUA  
(915) 330-0093,  
(915) 330-0093



# VIEWS

## SIDE VIEW

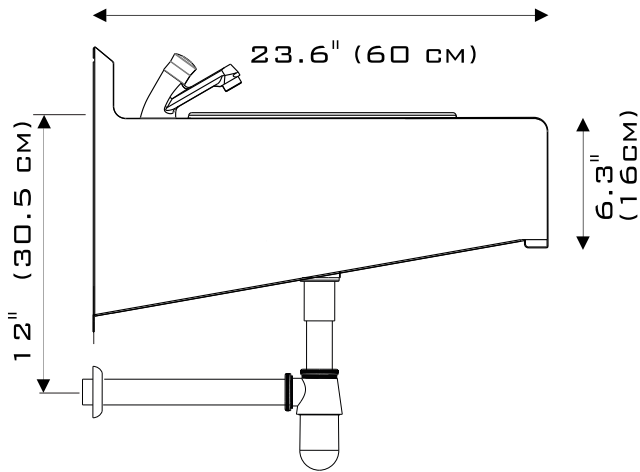

## PERSPECTIVE

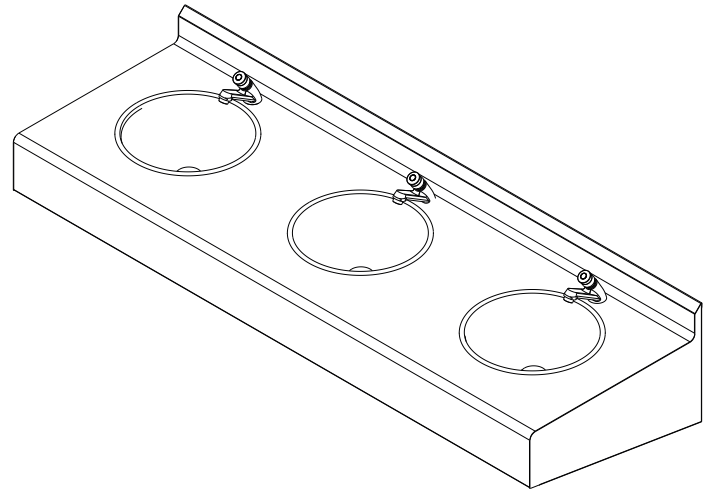

\* FAUCETS NOT INCLUDED.  
 \* FAUCET HOLES ARE SINGLE HOLE CENTRE 1 1/4" Ø (32 MM) PRE-DRILLED.  
 \* PLEASE TAKE NOTICE.

## TOP VIEW

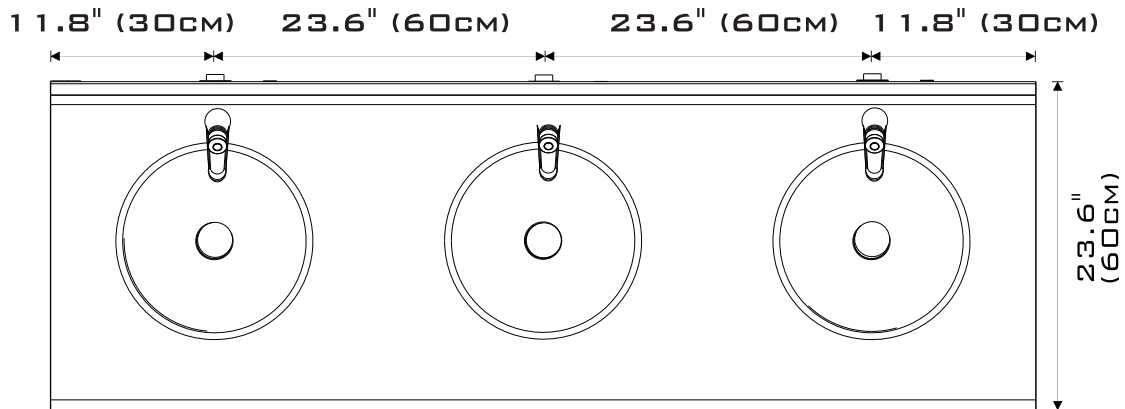

## FRONT VIEW

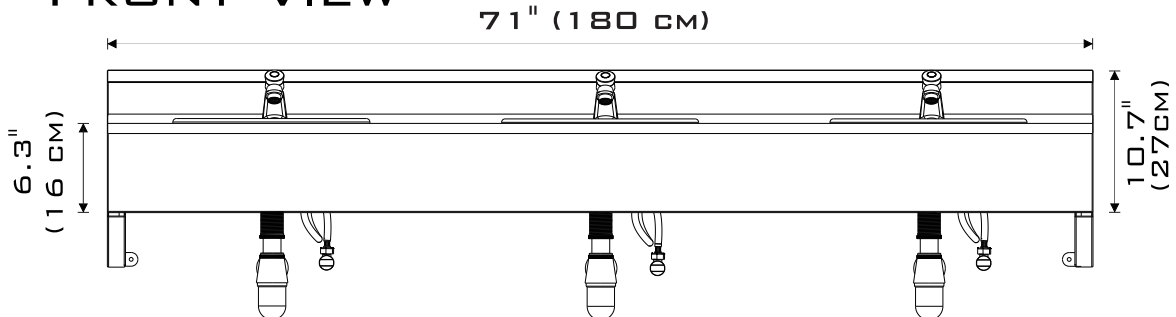



## INCLUDED ACCESSORIES

### STRAINER

- CONVENIENT BOTON LEVELED STRAINER
- BRASS SLIP AND LOCK NUTS
- SILICONE GASKETS TO AVOID LEAKS



### P-TRAP

- BRASS CHROME PLATED P-TRAP.



### SCREWS AND WALL ANCHORS

- 2, 2" x 3/8"  $\varnothing$  PLASTIC WALL ANCHORS
- 2, 2" x 1/4 "  $\varnothing$  SCREWS



- \* FAUCETS NOT INCLUDED.
- \* FAUCET HOLES ARE SINGLE HOLE CENTRE 1 1/4"  $\varnothing$  (32 MM) PRE-DRILLED.
- \* PLEASE TAKE NOTICE.



### INSTALLATION GUIDANCE

- ① PREPARE A 2" Ø DRAINAGE OUTLET AT 24" (61 CM) HIGH FROM THE FINISHED FLOOR LEVEL.
- ② USING AN SPIRIT LEVEL, DRAW A LINE AT 39.2" (99.5 CM) HIGH FROM THE FINISHED FLOOR LEVEL, NEAR THE SIDES OF THE LAVATORY. THIS LINE WILL MATCH WITH THE UPPER BACK OF THE LAVATORY.
- ③ MEASURE THE DISTANCE BETWEEN THE BACK KEY HOLES AND HELPED WITH THE 39.2" (99.5 CM) DRAWN LINE, DRAW THE KEY HOLES DRILL POSITION IN THE WALL.
- ④ ONCE MARKED THE KEY HOLES IN THE WALL, DRILL THEM WITH A 3/8" CONCRETE DRILL BIT, AND FIX THEM AFTER THE PLASTIC ANCHORS; LET A 2 MM GAP BETWEEN THE WALL AND THE SCREW HEAD, TO
- ⑤ FIT THE LAVATORY.
- ⑥ HANG ON THE LAVATORY. AFTER THAT, AND CONFIRMED THE P-TRAP FITS INTO THE WALL DRAINAGE, DRAW THE LOWER DRILL HOLES. DRILL THEM WITH A 3/8" CONCRETE DRILL BIT.
- ⑦ INSTALL FAUCETS, AND P-TRAP.

\* FAUCET NOT INCLUDED.  
 \* FAUCET HOLES ARE SINGLE HOLE CENTRE 1 1/4" Ø (32 MM) PRE-DRILLED.  
 \* PLEASE TAKE NOTICE.  
 \* IF SPECIAL FIXTURE NEEDED PLEASE INDICATE BEFORE PURCHASE.

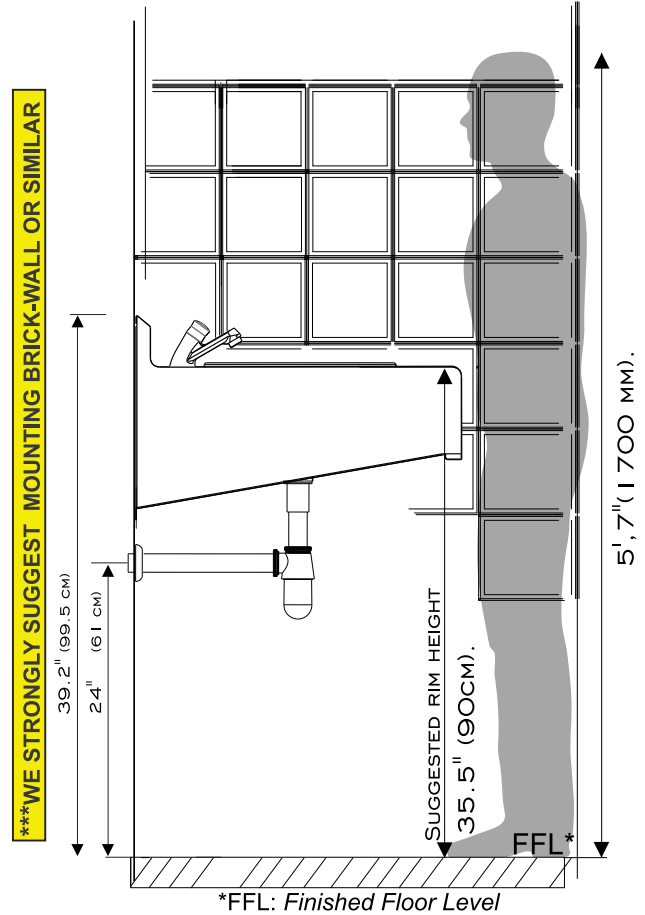

### CLEANING AND MAINTENANCE

THE 304 STAINLESS STEEL-FEED GRADE TYPE, NEEDS LESS MAINTENANCE THAN OTHER METALS, AND DOES NOT PRODUCE STAINS BY IT SELF OR BY THE SOLE WATER EXPOSURE, ALTHOUGH REGULAR CLEANING WILL PREVENT IT TO GET STAINED BY THE DIFFERENT CORROSIVE AGENTS, SUCH AS CHLORINE, SALT AND MINERALS DEPOSITS LEFT BY EVAPORATED WATER, ETC. THE FOLLOWING ARE INSTRUCTIONS IN ORDER TO KEEP YOUR STAINLESS STEEL SCRUB APPEARANCE AND FUNCTIONS PRESERVED.

1. ONLY USE WATER AND PLASTIC SCOURER TO CLEAN THE STAINLESS STEEL SURFACE, IF NEEDED, USE DISH SOAP, AND RINSE ANY RESIDUE.

2. DO NOT USE CHLORINE OR ANY PRODUCT WHICH INCLUDES IT, SINCE IT IS CORROSIVE TO METALS AND CAN DAMAGE THE STAINLESS STEEL SURFACE APPEARANCE AND EVEN THE STRUCTURE. IF CHLORINE USE IS UNAVOIDABLE; PLEASE RINSE IT COMPLETELY, AND CLEAN ALSO THE EXTERNAL LAVATORY SURFACE. CHLORINE DROPS CAN STAIN OR EVEN CORRODE STAINLESS STEEL. AVOID CHLORINE TO LEAK IN THE LAVATORY BACK BY SEALING IT IN THE COUNTERTOP. A COMMON SITUATION IS TO SPLASH CHLORINE FROM THE FLOOR WHILE MOPPING, SO BE AWARE OF CLEANING ALL CHLORINE, IF MOPPING WITH IT.

3. DO NOT USE SHARPENED OBJECTS TO CLEAN THE STAINLESS STEEL SURFACE, SINCE THIS WILL BRING ABOUT SCRATCHES.

4. DESPITE STAINLESS STEEL NEEDS LESS MAINTENANCE THAN OTHER METALS, IF YOU CLEAN UP AND DRY IT COMPLETELY ONCE ON A DAILY BASIS, OR AT LEAST TWICE A WEEK; THE STAINLESS STEEL APPEARANCE WILL LAST FOR LONGER TIME.

[www.stainlessad.com](http://www.stainlessad.com)

4673 Osborne Dr,  
 El Paso TX, EUA  
 (915) 330-0093,  
 (915) 330-0093