



STAINLESS-AD

# COLLECTIVE URINAL Tu2



## characteristics

material s. steel  
type 304  
gauge 20 (0.9 mm)  
finish 2b

## measures

length: 39.4" (100.0 cm)  
width 12.0" (30.0 cm)  
height 13.8" (35.0 cm)

## mounting system

02 built in backup levelers  
02 2" x 3/8" Ø plastic anchors  
02 2" x 1/4" Ø screws

## features

.seamless welded  
.vandal resistant  
.to be used in schools,  
clinics, hospitals, etc.

[www.stainlessad.com](http://www.stainlessad.com)

4673 Osborne Dr,  
El Paso TX, EUA  
(915) 330-0092,  
(915) 330-0093

STAINLESS AMERICAN DESIGNS, INC.



STAINLESS-AD

# COLLECTIVE URINAL Tu2



## characteristics

material s. steel  
type 304  
gauge 20 (0.9 mm)  
finish 2b

## measures

length 39.4" ( 100.0 cm)  
width 12.0" ( 30.0 cm)  
height 13.8" ( 35.0 cm)

## mounting system

02 built in backup levelers  
02 2" x 3/8" Ø plastic anchors  
02 2" x 1/4 Ø screws

## features

.seamless welded  
.vandal resistant  
.to be used in schools,  
clinics, hospitals, etc.

[www.stainlessad.com](http://www.stainlessad.com)

4673 Osborne Dr,  
El Paso TX, EUA  
(915) 330-0093,  
(915) 330-0093



# STAINLESS-AD COLLECTIVE URINAL TU2

## SIDE VIEW VIEWS FRONT VIEW

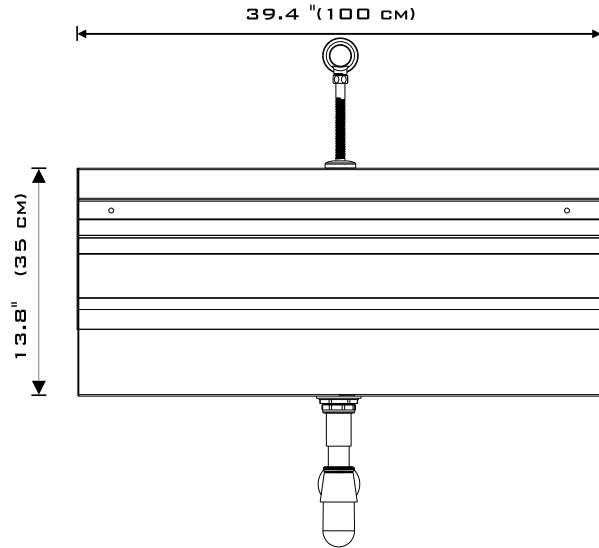
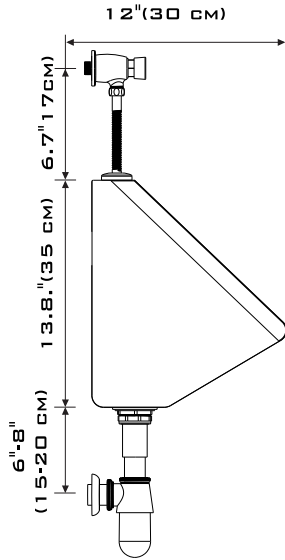

## TOP VIEW

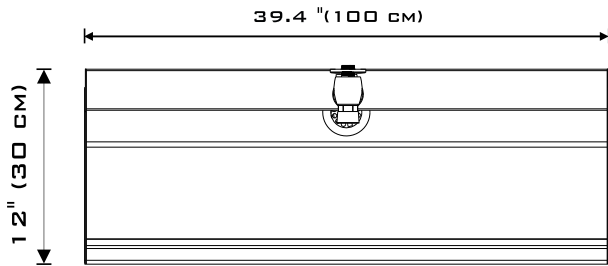

## BACK VIEW

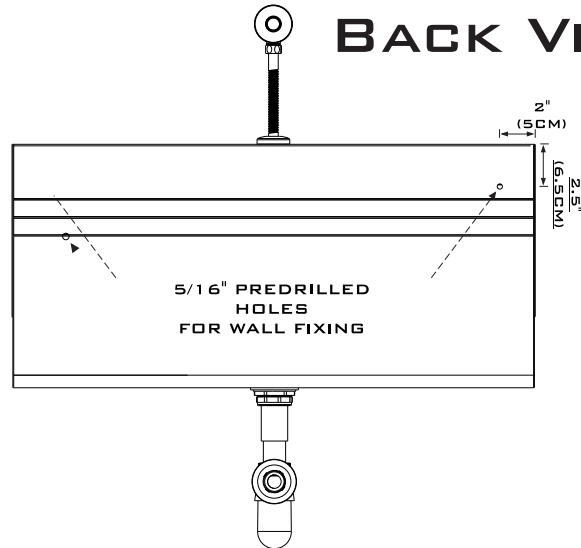

## PERSPECTIVE

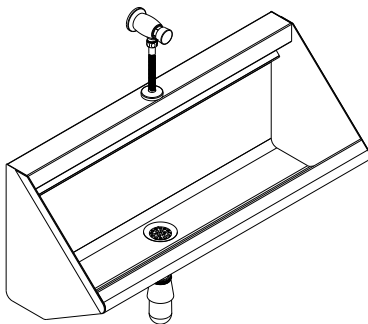

[www.stainlessad.com](http://www.stainlessad.com)

4673 Osborne Dr,  
El Paso TX, EUA  
(915) 330-0093,  
(915) 330-0093



STAINLESS-AD

COLLECTIVE URINAL TU2

## INCLUDED ACCESSORIES

### TIME DELAY FLUSH VALVE

- SELF CLOSING BUTTON
- BRASS CHROME PLATED
- (WATER PRESSURE NEEDED, 9-24 PSI)



### URINAL STRAINER

- CONVENIENT URINAL STRAINER
- DRILLED CAP TO AVOID OBSTRUCTION
- BRASS SLIP AND LOCK NUTS



### P-TRAP

- BRASS CHROME PLATED P-TRAP, WITH SS STRAINER CONNECTION.



### SCREWS AND WALL ANCHORS

- 2, 2" x 3/8"  $\varnothing$  PLASTIC WALL ANCHORS
- 2, 2" x 1/4 "  $\varnothing$  SCREWS



[www.stainlessad.com](http://www.stainlessad.com)

4673 Osborne Dr,  
El Paso TX, EUA  
(915) 330-0093,  
(915) 330-0093



# STAINLESS-AD COLLECTIVE URINAL TU2

## INSTALLATION GUIDANCE

- ① PREPARE THE ADECUATED DRAINAGE 2" OUTLET.
- ② MAKE SURE WATER PRESSURE IS 9 TO 24 PSI.
- ③ USING AN SPIRIT LEVEL, AND ACCORDING TO THE DESIRED URINAL RIM HEIGHT, HOLD THE URINAL AGAINST THE WALL IN THE FINAL POSITION AND DRAW THE WALL WITH A PENCIL THROUGH THE HANG DRILL HOLES.
- ④ IN ORDER TO PROPERLY URINAL WALL FLUSH FUNCTIONS, SPIRIT LEVEL IS NECESSARY; SINCE YOUR URINAL DOES NOT USE PIPE WATER DISTRIBUTOR BUT A TROUGH TO AVOID MINERAL OBSTRUCTION.
- ⑤ ONCE MARKED THE WALL HOLES TO DRILL, AND CONFIRMED THE P-TRAP FITS INTO THE WALL DRAINAGE, AS WELL AS THE TIME DELAY FLUSH VALVE DOES IT TOO INTO THE WALL INTAKE; DRILL THE MARKED HOLES IN THE WALL WITH A 3/8" Ø CONCRETE DRILL BIT, SET THE WALL ANCHORS, AND FINALLY, FIX THE URINAL WITH THE PROVIDED SCREWS.
- ⑥ IN THE CASE OF RECENTLY INSTALLED PIPES, GET SURE THERE IS NO DEBRIS IN THEM, SINCE THIS CAN PREVENT TIME DELAY FLUSH VALVE TO WORK RIGHTLY.
- ⑦ DO NOT POUR OTHER LIQUIDS THAN URINE OR WATER INTO THE URINAL, SUCH AS COFFE, PAINT, OIL, ETC; BY DOING SO THE STAINLESS STEEL'S APPERANCE MIGHT BE DAMAGED IN RESULT IF IT IS NOT PROPERLY WASHED, AND MAY DECREASE THE P-TRAP'S LIFE SERVICE.

PLEASE TAKE NOTICE OF THE DRAINAGE OUTLET HEIGHT, SINCE P-TRAP IS ADJUSTABLE

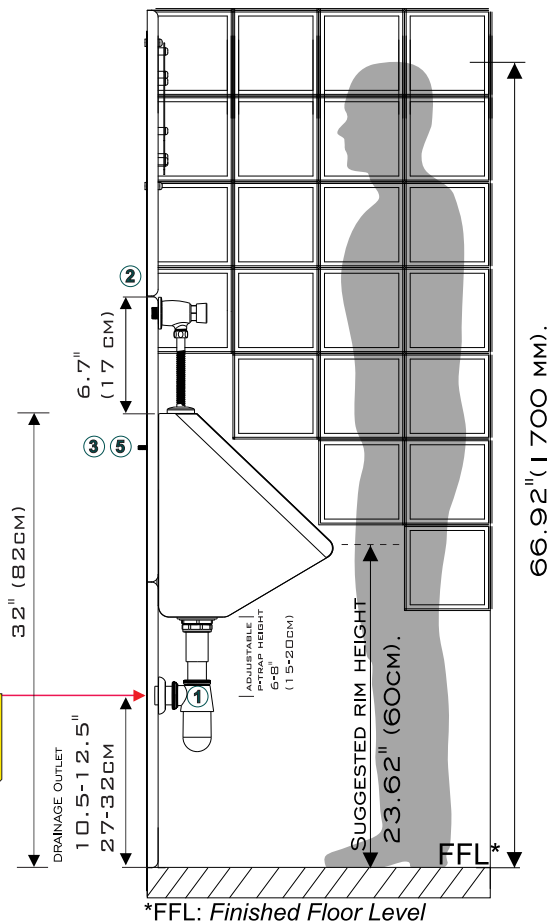

## CLEANING AND MAINTENANCE

THE 304 STAINLESS STEEL GRADE TYPE, NEEDS LESS MAINTENANCE THAN OTHER METALS, ALTHOUGH REGULAR CLEANING WILL PREVENT IT FROM FORMING TARTAR, AS WELL AS SALT AND MINERAL DEPOSITS (STAINS) LEFT BY REGULAR OR HARD WATER AFTER EVAPORATED. (HARD WATER, IS THE NAME WATER RECEIVES WHEN A HIGH CONCENTRATION OF MINERALS IS PRESENT IN IT). THE FOLLOWING ARE INSTRUCTIONS IN ORDER TO KEEP YOUR STAINLESS STEEL URINAL'S APPEARANCE AND FUNCTIONS PRESERVED.

- 1- ONLY USE WATER AND PLASTIC SCOURER TO CLEAN THE STAINLESS STEEL SURFACES, IF NEEDED, USE LIQUID DISH SOAP, AND RINSE ANY RESIDUE.
2. DO NOT USE CHLORINE OR ANY PRODUCT WHICH INCLUDES IT FOR THE CLEANING OF STAINLESS STEEL, SINCE CHLORINE IS CORROSIVE TO METALS AND CAN AFFECT THE STAINLESS STEEL APPEARANCE. IF IT'S NECESSARY TO SANITIZE STAINLESS STEEL WITH CHLORINE, MIX IT WITH 90% OF WATER, AND BE SURE TO RINSE ALL OF IT, AVOIDING THE DIRECT UNDILUTED CHLORINE USAGE.
3. DO NOT USE SHARPENED OBJECTS TO CLEAN THE STAINLESS STEEL SURFACE, SINCE THIS WILL BRING ABOUT SCRATCHES.
4. IF WATER DOES NOT WASH ENTIRELY THE URINAL WALL'S SURFACE AFTER VALVE'S FLUSHING; SCRUB URINAL WALLS WITH LIQUID DISH WASHER SOAP AND A PLASTIC SCOURER, CAUSE OIL OR GREASE STAINS WILL AVOID WATER FROM ENTIRELY WASH THE URINAL'S WALL, SINCE OIL AND GREASE ARE HYDROPHOBIC.

[www.stainlessad.com](http://www.stainlessad.com)

4673 Osborne Dr,  
El Paso TX, US  
(915) 330-0093,  
(915) 330-0093